

Specification (Test Condition, 25°C)

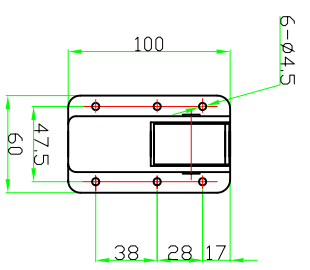
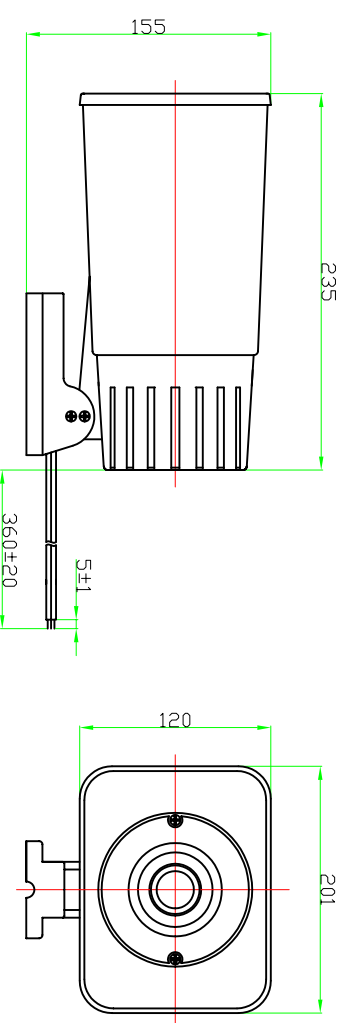

1. Housing Material/ Color..... ABS / White
2. Voice Coil Impedance 8 Ohm (at 1 KHz)
3. Voice Coil Dimension Ø 33 mm(Dia.)
4. Magnet Size Ø 80x40x12mm(Dia.* dia.*H)
5. Power Rating RMS 20 W
6. Power Rating Peak 25 W
7. Frequency Range 800-8000Hz
8. Resonant Freq. Fo. 1.5 KHz ±10%
9. S.P.L. 100 dB(at 1 meter, 2.83V, 1000Hz)
10. Wires Connection Black, white (Non-polarized)
11. Weight 1050 ±10 g

No.		DESCRIPTION	APPROVED	DATE	DSW NINGBO DSW AUDIO & SECURITY EQUIPMENT http://www.dswbrand.com	
<small>FOR THE OVERSEAS MARKETS</small> <small>XXX #</small> <small>90° FORMED ±2°</small> <small>FIRST ANGLE PROJECTION</small>		APPROVALS			UNIT	DWG. NO.
		DRAWN			mm	E3.840.005
		CHECKED			SCALE	SHEET
		APPROVED		04.02.10	NOT TO SCALE	VER 1.0