

Specification (Test Condition, 25°C)

1.SCOPE

This specification is applied to the piezoelectric diaphragm.

2.SPECIFICATION (at 25 °C)

MODEL	FT-24T-3.0A1	FT-24T-5.6A1
Resonant Frequency (KHz)	3.0±0.5	5.6±0.5
Resonant Resistance(Ω)	200	400
Capacitance	45000±30%	22000±30%
D	24±0.2	24±0.2
d	20±0.3	20±0.3
T	0.22±0.05	0.48±0.05
t	0.10±0.02	0.23±0.02

Input Voltage : 30 Vp-p max
 Operating Temperature : -20 to +50°C
 Storage Temperature : -20 to +70°C
 Dimension : as per Figure 1.

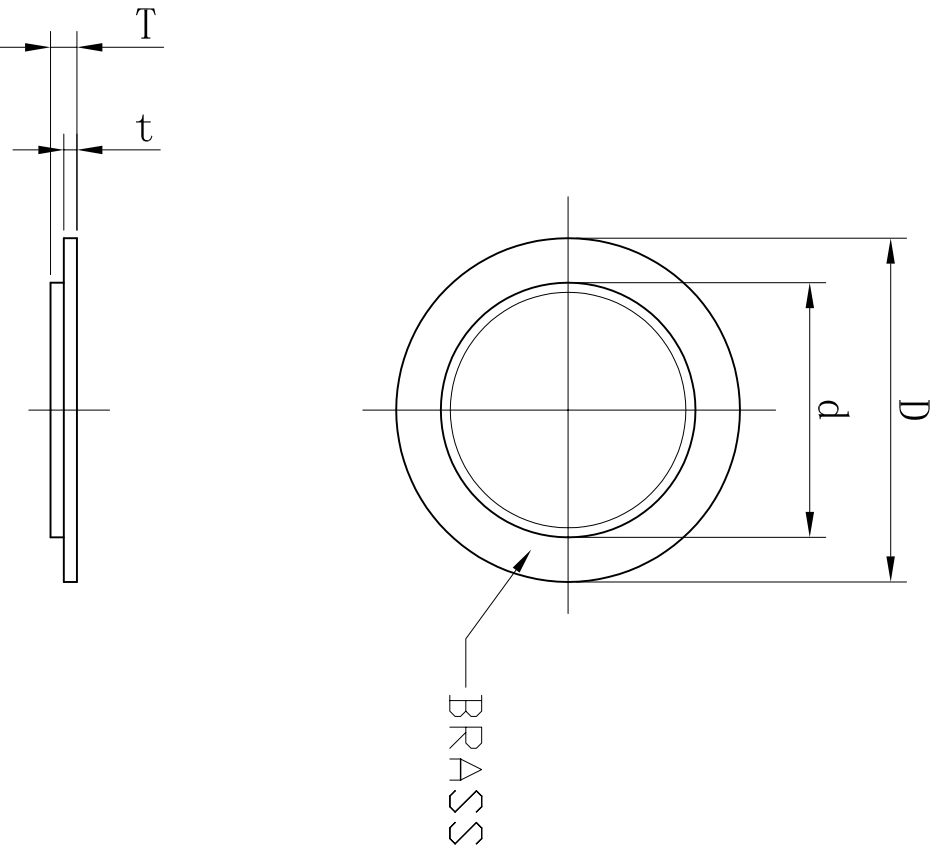

 NINGBO DSW AUDIO & SECURITY EQUIPMENT http://www.dswbrand.com fax:+86(574)87264906		UNIT: mm SCALE: NOT TO SCALE	
Piezoelectric Diaphragm FT-24T-3.0(5.6)A1		DWG NO: E4.845.004	
No.	DESCRIPTION	APPROVED	DATE
COILED OVERBURNERS X # XX # XXX # 90°FORMED ±2° ANGLES ±2° FIRST ANGLE PROJECTION		DRAWN	CHECKED
APPROVALS		APPROVED	DATE
04.04.09		SHEET	